

bMusic

Motivation

How do you create a tool to capture transient experience?

How can you better share reaction with those around you?

How can you save your emotional response for later recall?

Inspiration

Stelarc - Expanding corporal periphery

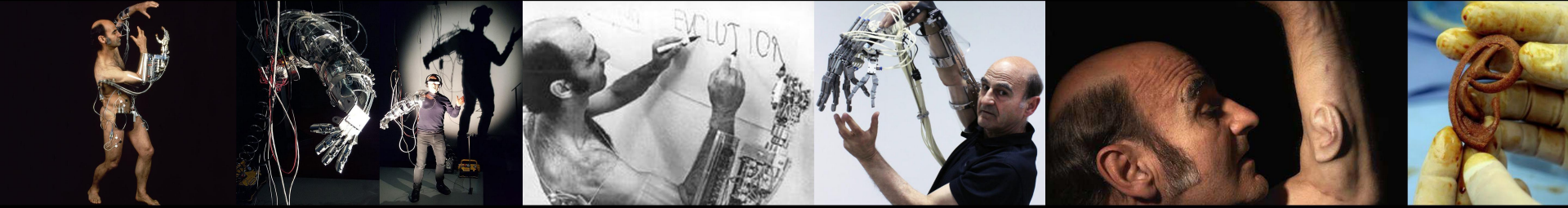

Pierre Henry - Cortical Art

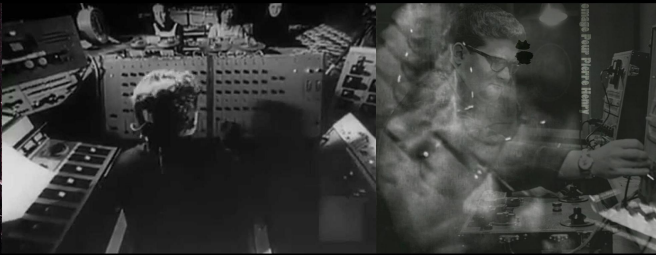

Process

Brush

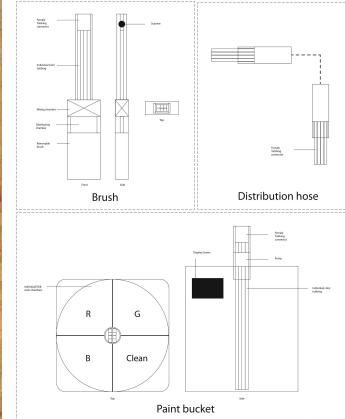
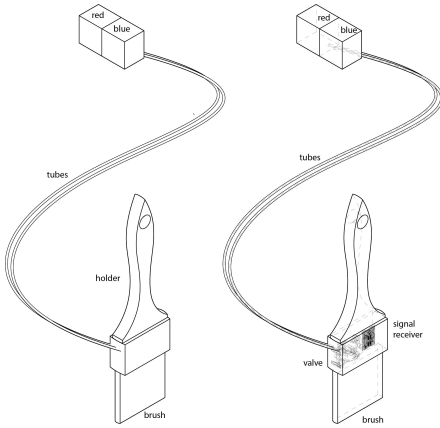



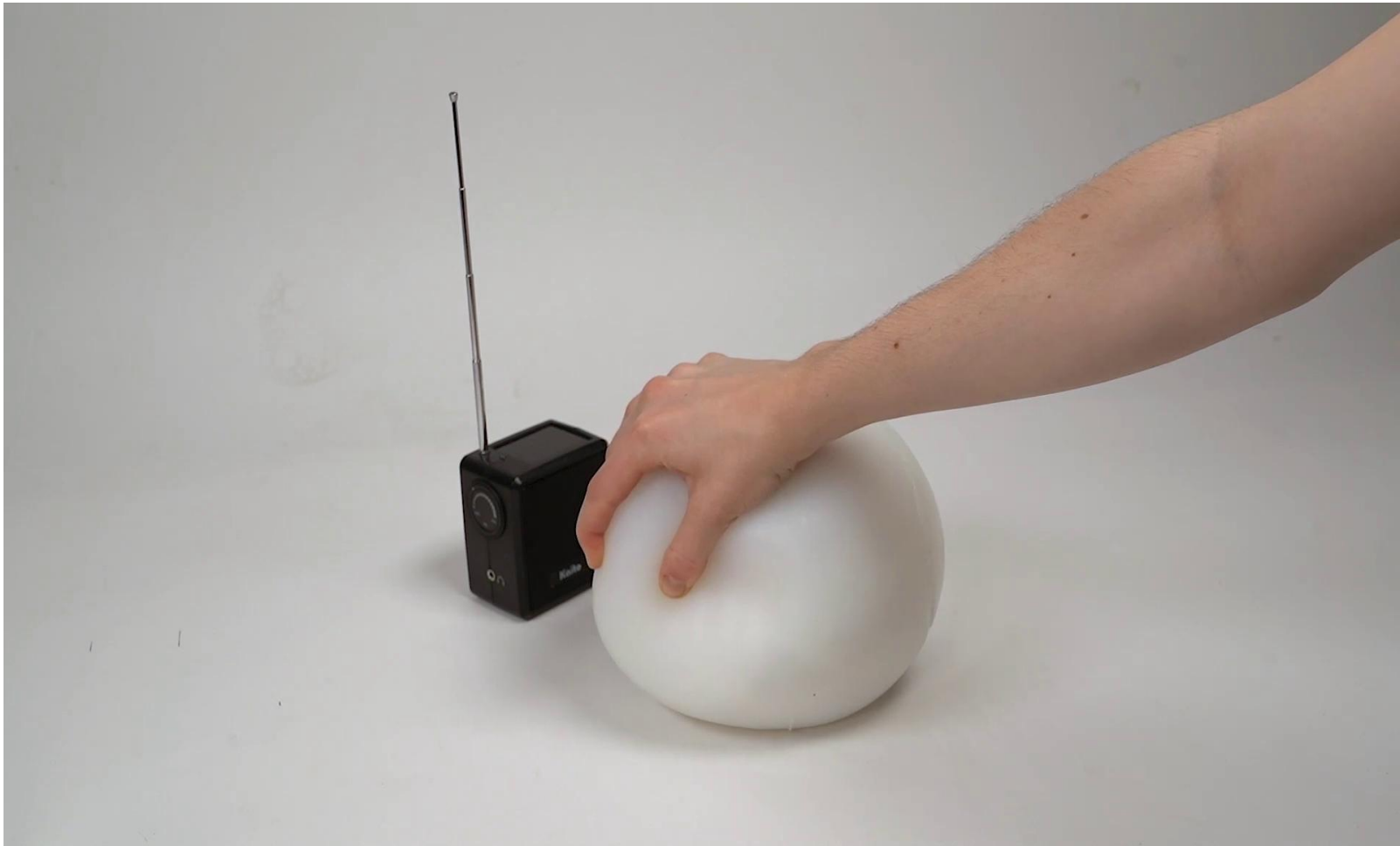

Final Concept

A Tool To:

- Express changes in arousal through music.
- Express changes in mperceivable to people other than yourself.
- Record experiences as a memento.
- Be worn by someone performing, like a dancer.
- Give haptic feedback when your bio-data reaches extremes.



Functional Diagram

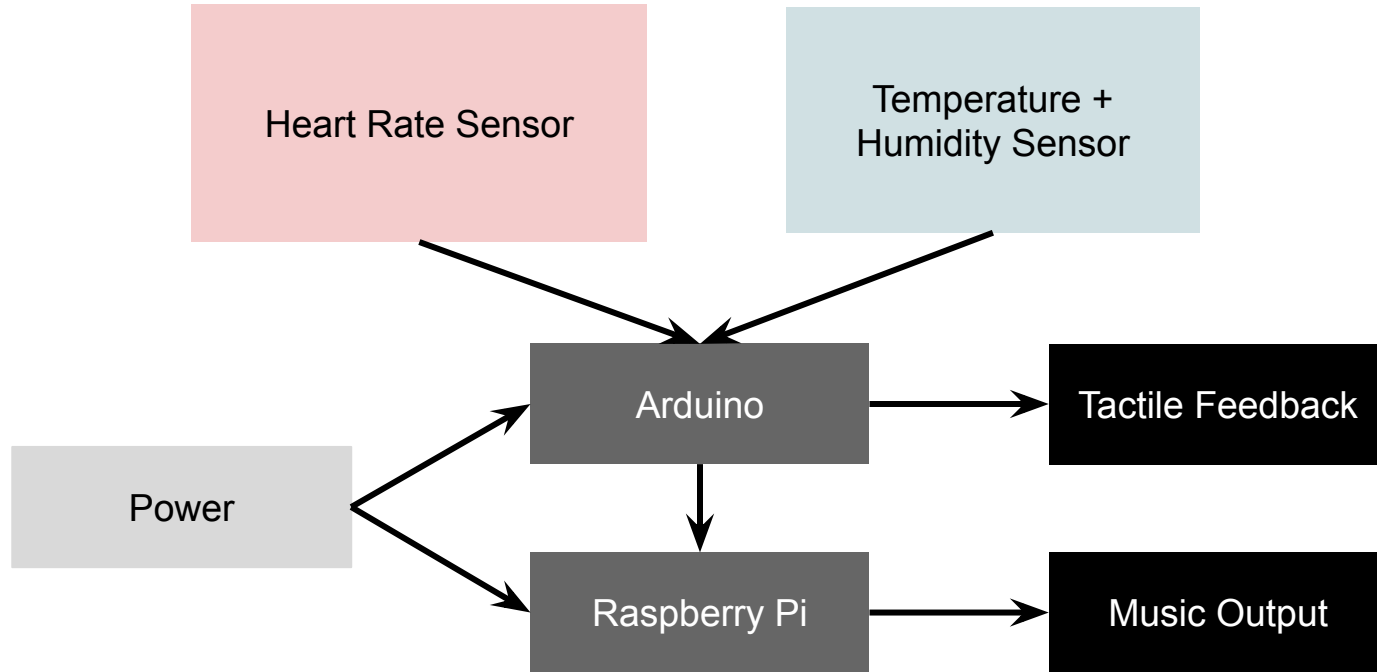

Prototyping

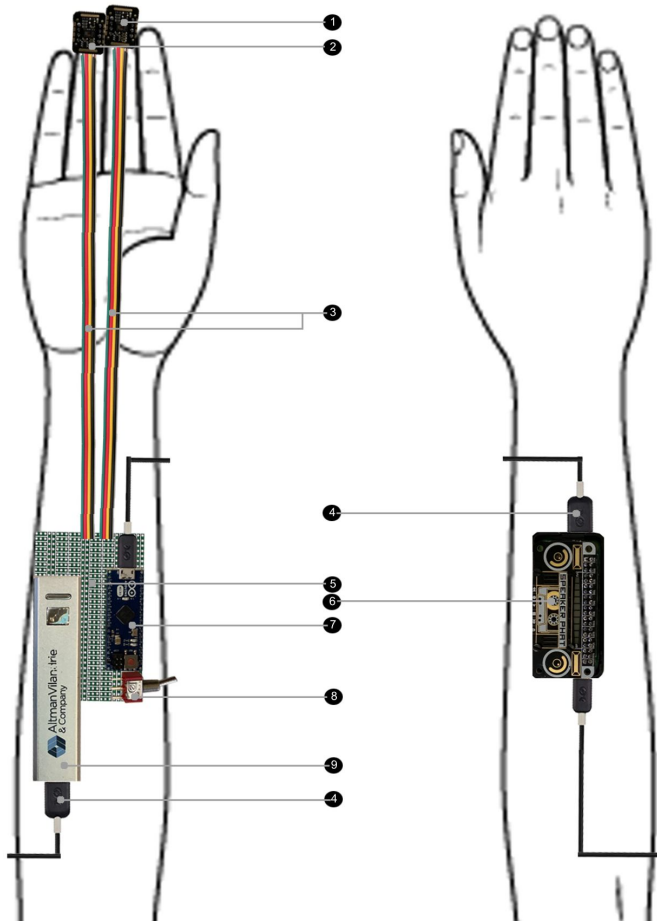

1. Heart rate sensor
2. Temperature/humidity sensor
3. Sensor cables
4. USB cables
5. Circuit board
6. Raspberry pi
7. Arduino
8. On/off Switch
9. Battery

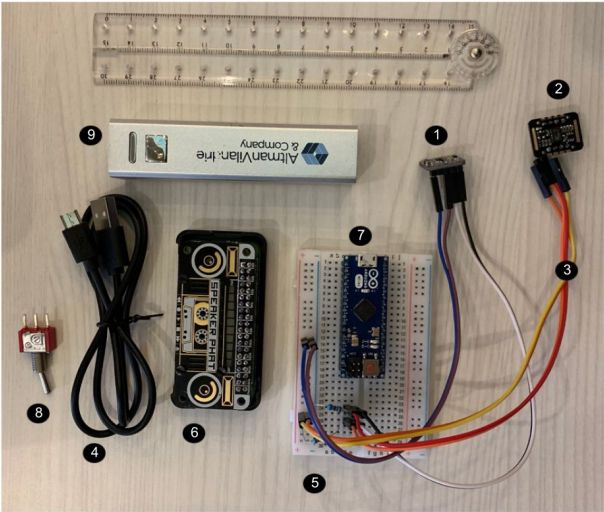
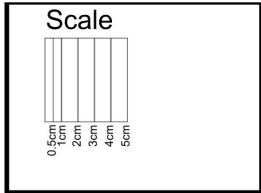

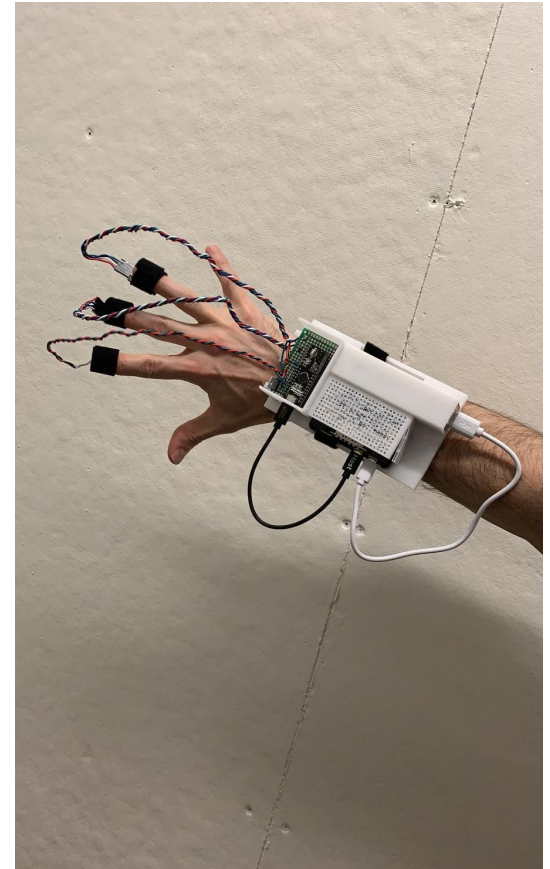
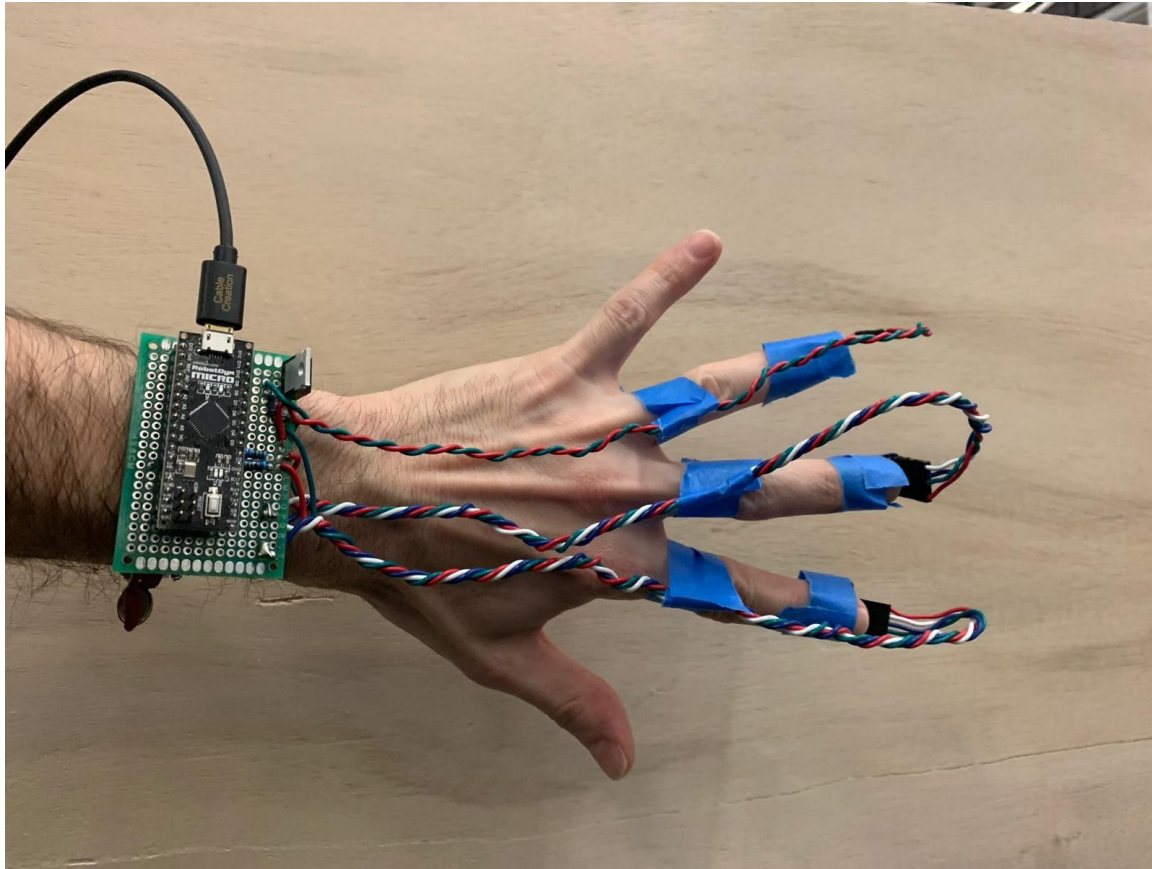

Final Prototype

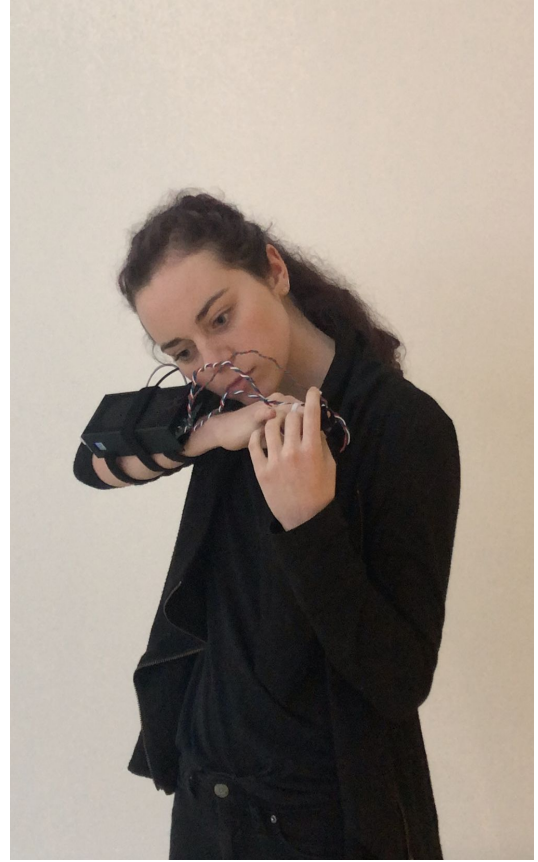

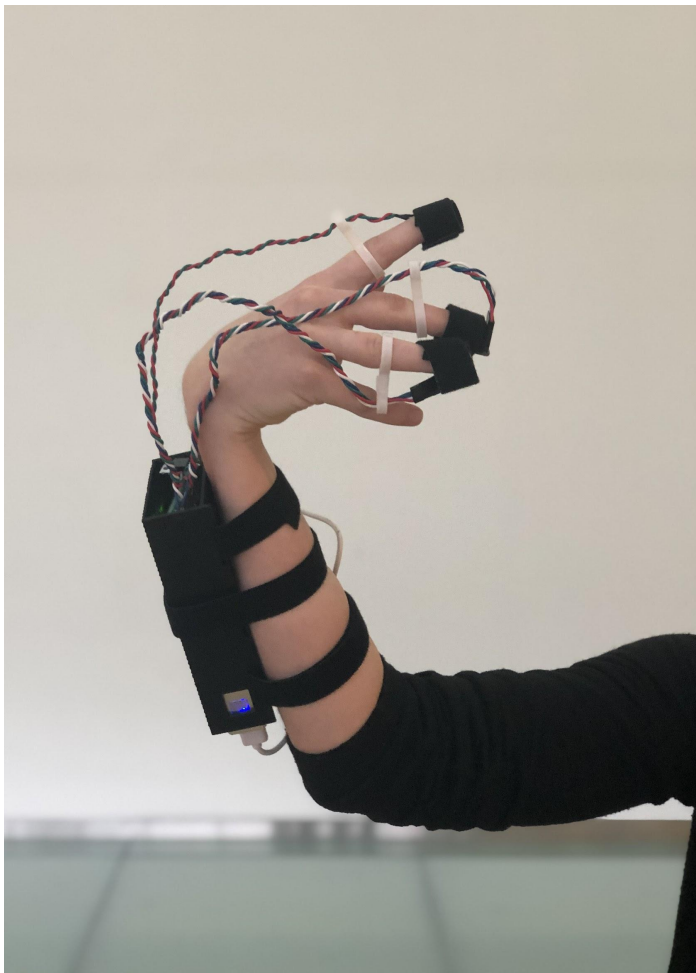



Bio-Music

- Pure Data was used for music generation
- Increasing temperature & humidity is positively correlated with two frequencies
- Could trigger sound bites instead
- Heart rate could be integrated as a third frequency, or as a beat overlay

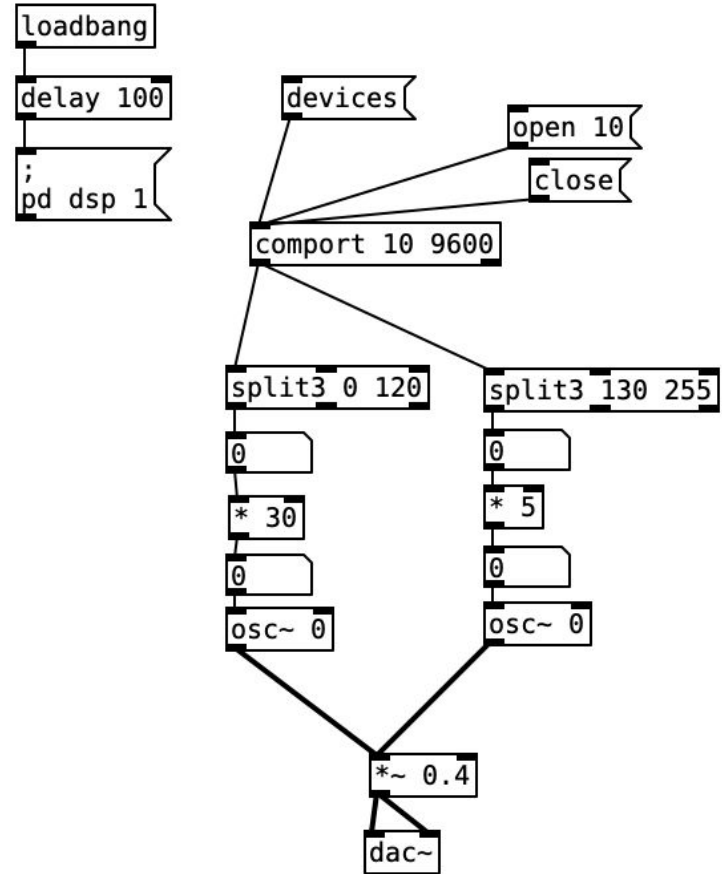

Haptic Feedback

- Used vibration to indicate extremes in bio data
- Vibration can be intense, which forces the user to think about and/or change their movements
- Currently implemented for temperature

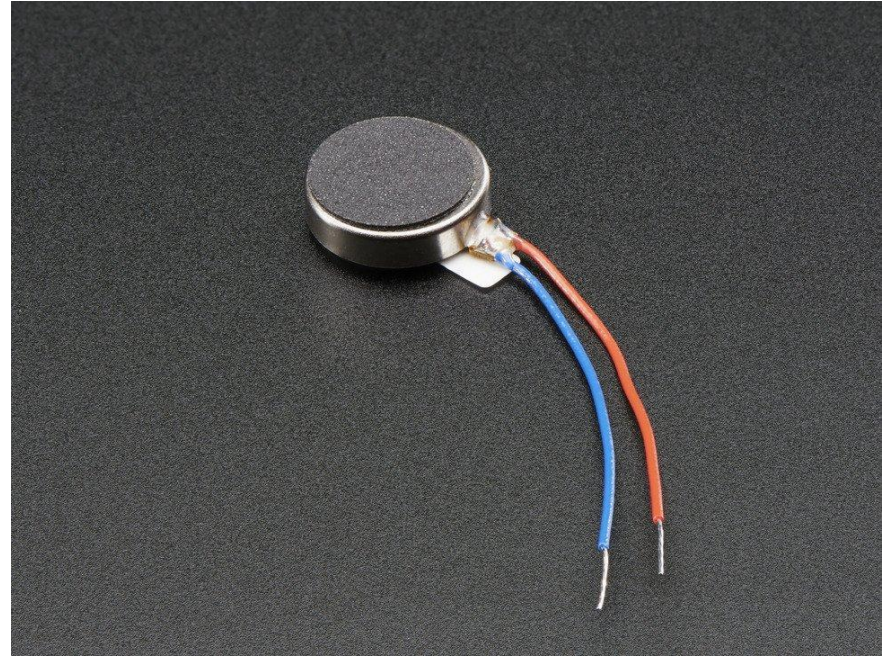

Future Work

Future Prosthetic Design

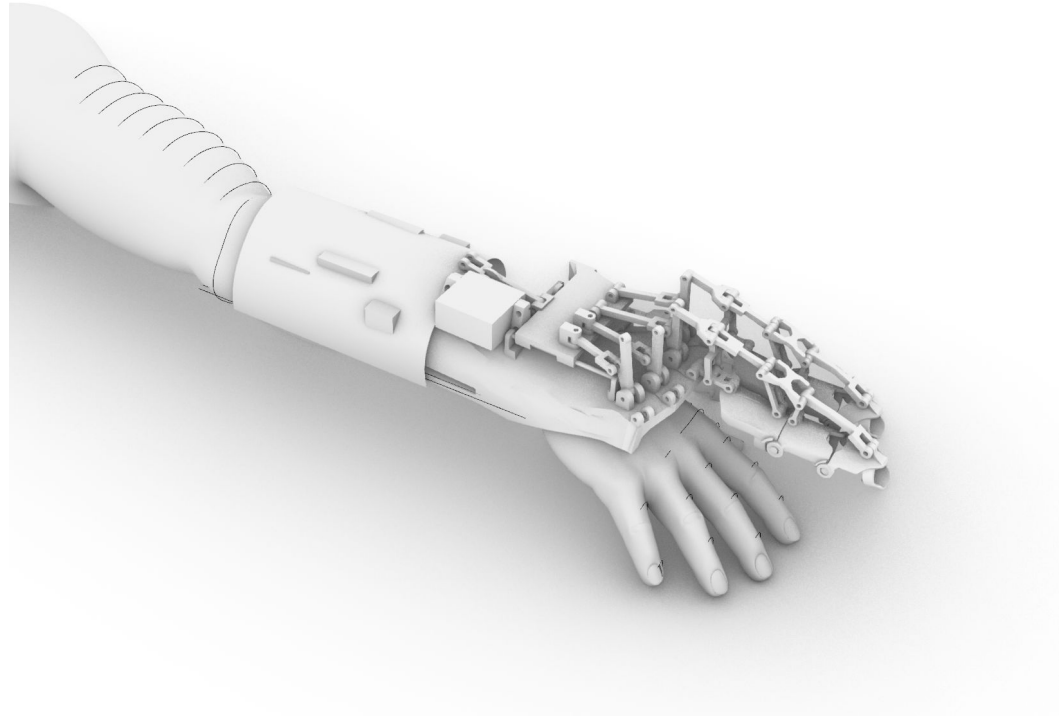
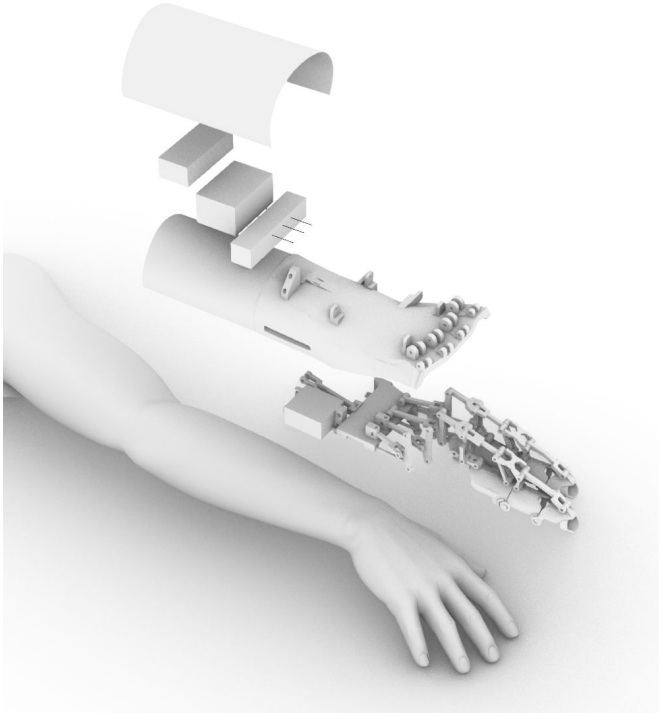

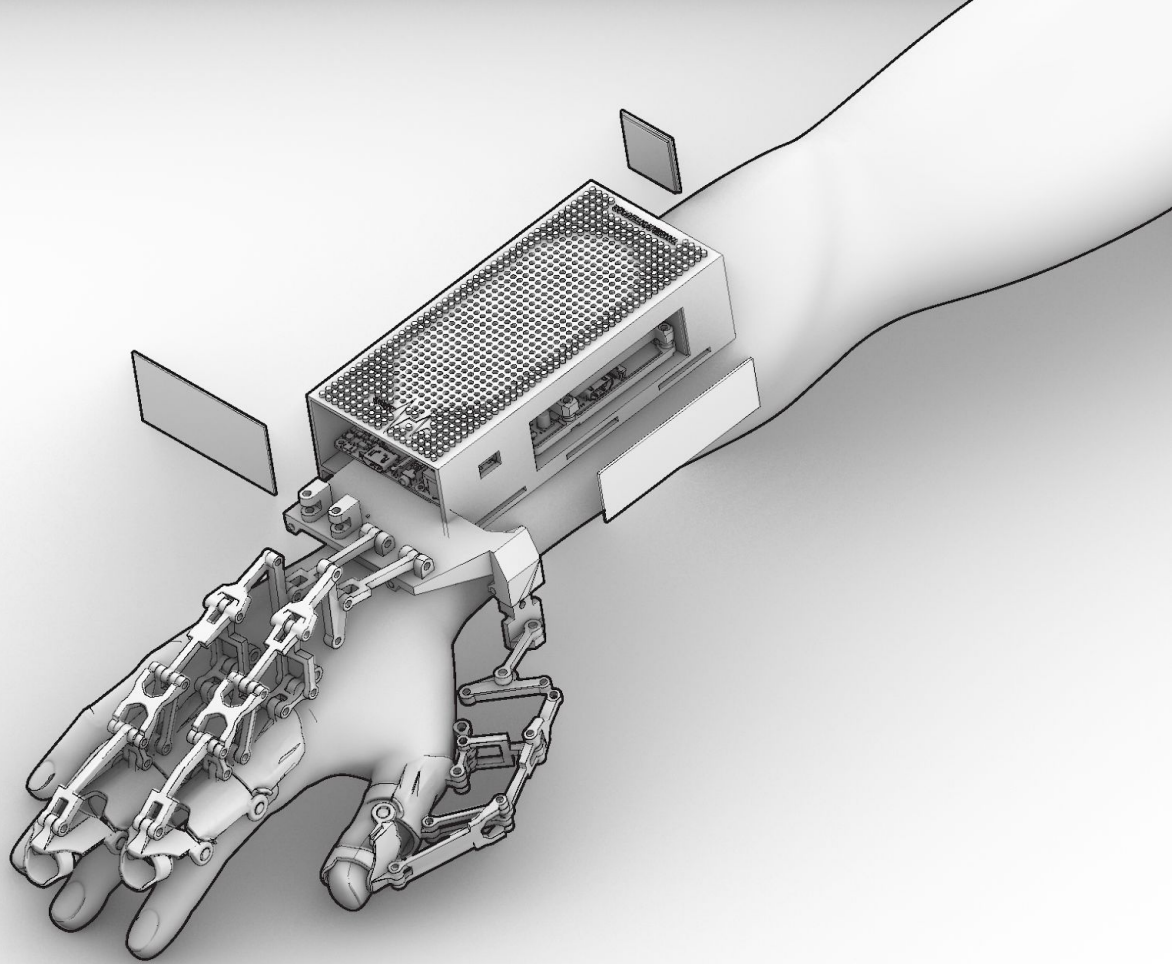

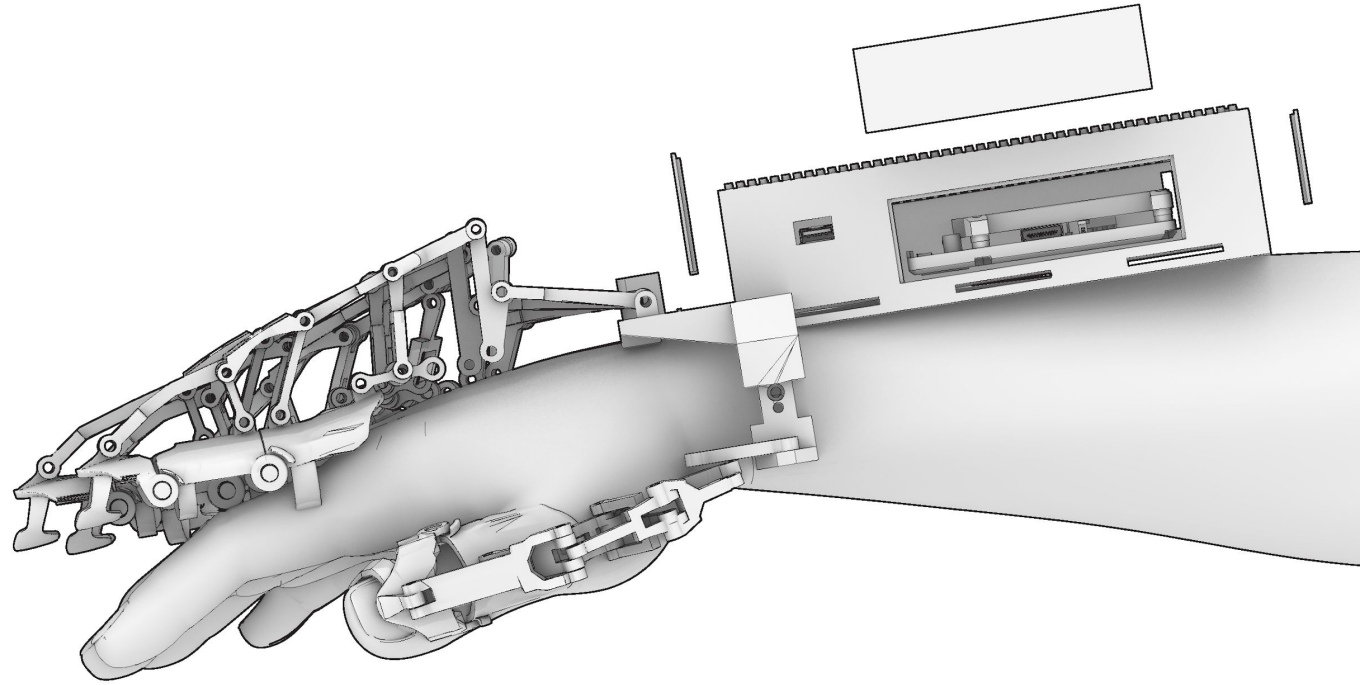

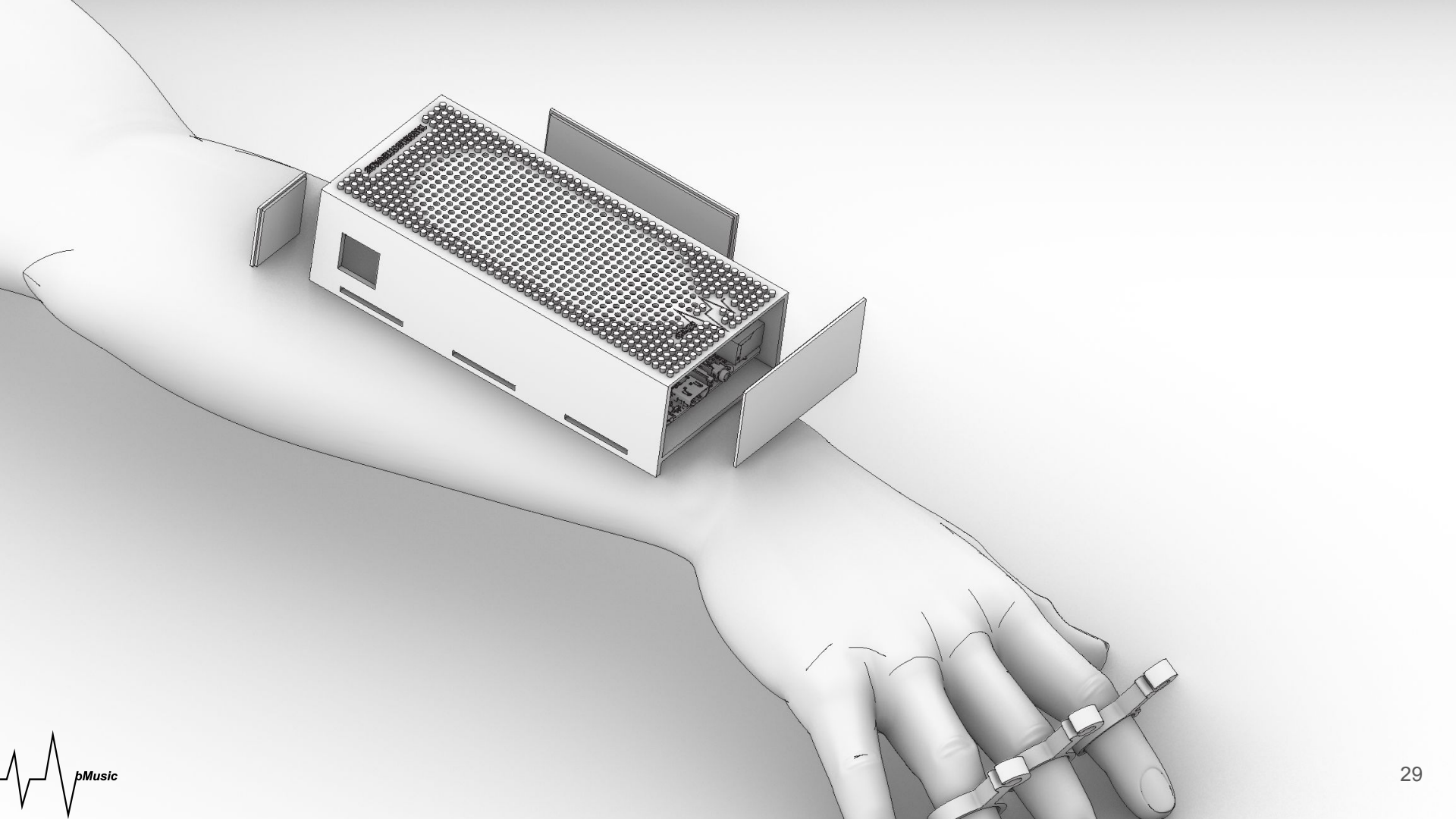

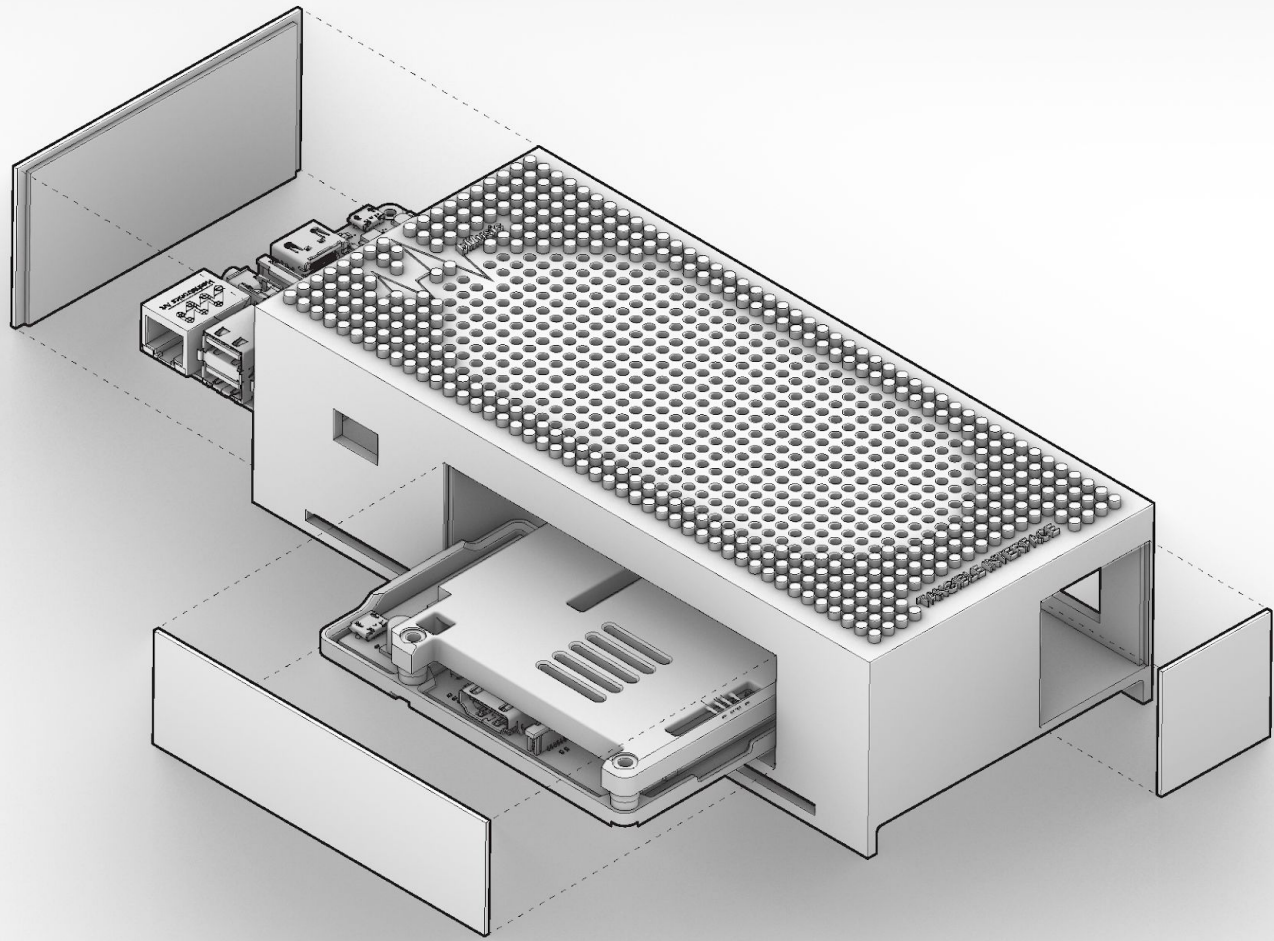

Future Function Iterations

- New sensor data (galvanic skin response, heart rate, inertia) to make more complex music
- Map inputs to a preselected musical structure (eg. key or genre) instead of pure tones
- Provide additional affordances to the user for more curated expression
 - Select bio-music output mode, genre, volume, etc.
 - Select between public playback, private playback, or storage



Future Function Iterations Cont'd

- If two people use it and their bodies come into contact, this could also influence the generated music
- Animal-like responses from the glove
- More streamlined design



Live Demo

Thank You

